

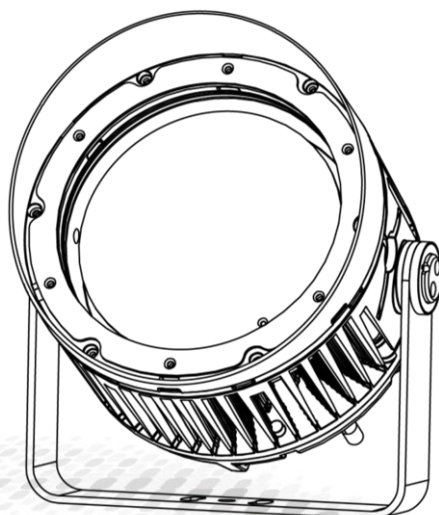

创意源于追求
Own Idea Of Lighting

PIXI PRO USER MANUAL

arctik[®] PIXI PRO
ARCHITECTURAL TECHNOLOGY AM1441



MODEL: AM1441XCT/XAT/XWT/XNT/XLT



广州市雅江光电设备有限公司
Guangzhou Yajiang Photoelectric Equipment Co., Ltd.
电话/Tel: 020-86947788 邮箱/E-mail: sales@yajiang.cn
传真/Fax: 020-86943773 网址/Website: www.yajiang.cn

1 PRODUCT

1.1 TECHNICAL SPECIFICATIONS

Type	AM1441XCT/XAT/XWT/XNT/XLT
Power	120W
Voltage Range	AC100~240V,50/60Hz
Protection	IP67
Operation Temperature	-20°C~45°C
Dimensions	284x250x283mm
Weight	8.4kg

DIMENSIONS

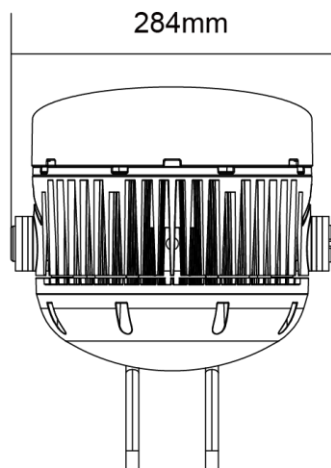
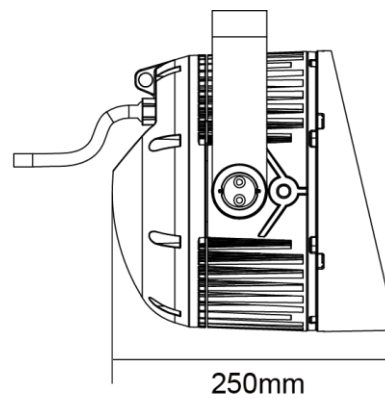
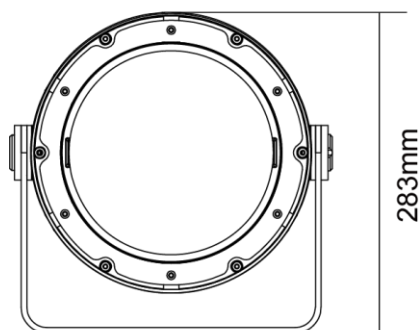

1.2 Safety Notes

IMPORTANT

- This product must be installed by a qualified professional.
- In order to maintain this condition and to ensure safe operation, it is absolutely necessary for the user to follow the safety instructions and warning notes
- The manufacturer will not accept liability for any resulting damages caused by the non-observance of this manual or any unauthorized modification to the device.

CAUTION!

- Make sure that the available voltage is not higher than stated on the rear panel.
- Do not touch the power cables if your hands are wet.
- The earth wire must always be connected to the ground. Therefore it is essential to connect the yellow/green conductor to earth.
- Make sure that the power-cord is never crimped or damaged by sharp edges. Check the device and the power-cord from time to time. The electric connection, repairs and servicing must be carried out by a qualified employee.
- Always disconnect power input cable to completely remove power from unit when not in use or before cleaning or servicing the fixture.
- Do not switch the fixture on and off in short intervals as this would reduce the lamp's life.
- Do not touch the device's housing bare hands during its operation (housing becomes hot)! The surface of the product's casing can reach up to 70° C (158° F) during operation. Avoid contact by persons and materials. Do not install the product in a location where there is a risk of accidental contact. Allow the product to cool for at least 10 minutes before handling.
- For replacement use lamps and fuses of same type and rating only.
- Please protect the fixture and avoid destroy during transport and installation. If there is any damage to the coating, the shell may be corroded.
- When hanging lamps and lanterns, it is necessary to verify that facilities and hooks can bear at least 10 times the weight of lamps and lanterns.
- Fix the safety rope at the correct holes only. Only operate the fixture after having checked that the housing is firmly closed and all screws are tightly fastened.
- The maximum ambient temperature 45°C must never be exceeded. Do not operate the product if the ambient temperature (Ta) exceeds 45° C (115° F).
- The minimum ambient temperature (Ta min.): -40° C.
- When the temperature reaches the above upper limit, the fixture regulates output to protect from overheating.

Electrical Warning

- The light source contained in this luminaire shall only be replaced by the manufacturer or his service agent or a similar qualified person

2 INSTALLATION

2.1 MOUNTING

HANGING

- ◆ You could place the light on the floor. Please make sure the surface is plane and the reliability of the floor is sufficient.
- ◆ Bolt a rigging clamp securely to the mounting yoke. The bolts used must be M12, grade 8.8 steel minimum, and fastened with a self-locking nut.

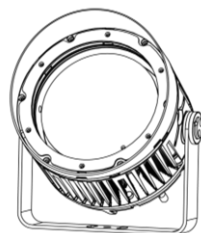

Horizontal layout

2.2 POWER CONNECTIONS

- ◆ This product has an auto-ranging power supply that can work with an input voltage range of 100–240 VAC, 50/60 Hz.

AC Plug

Connection	Wire (U.S.)	Wire(Europe)	Screw Color
AC Live	Black	Brown	Yellow/Brass
AC Neutral	White	Blue	Silver
AC Ground	Green/Yellow	Green/Yellow	Green

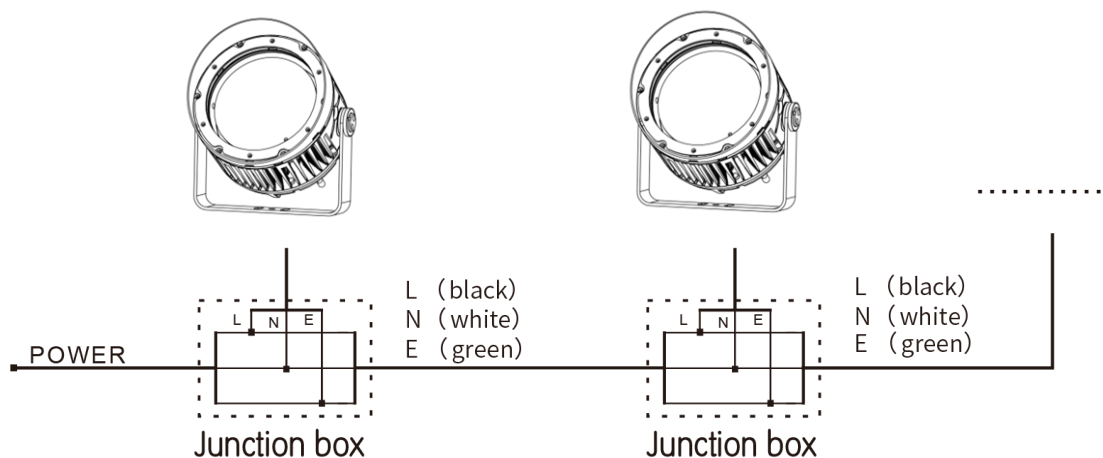

2.3 Data network requirements

- ◆ Connect the DMX512 controller to the units in series. A DMX 512 data link is required in order to control the fixture via DMX. The fixture has 3/5-pin XLR connectors for DMX data input and output.
- ◆ Each unit has 13 DMX channels so the DMX Addresses should increase by increments of 1, (Nx1)+1, (Nx2)+1, (Nx3)+1...
- ◆ Any DMX address in the range from 001 to 512 may be used.

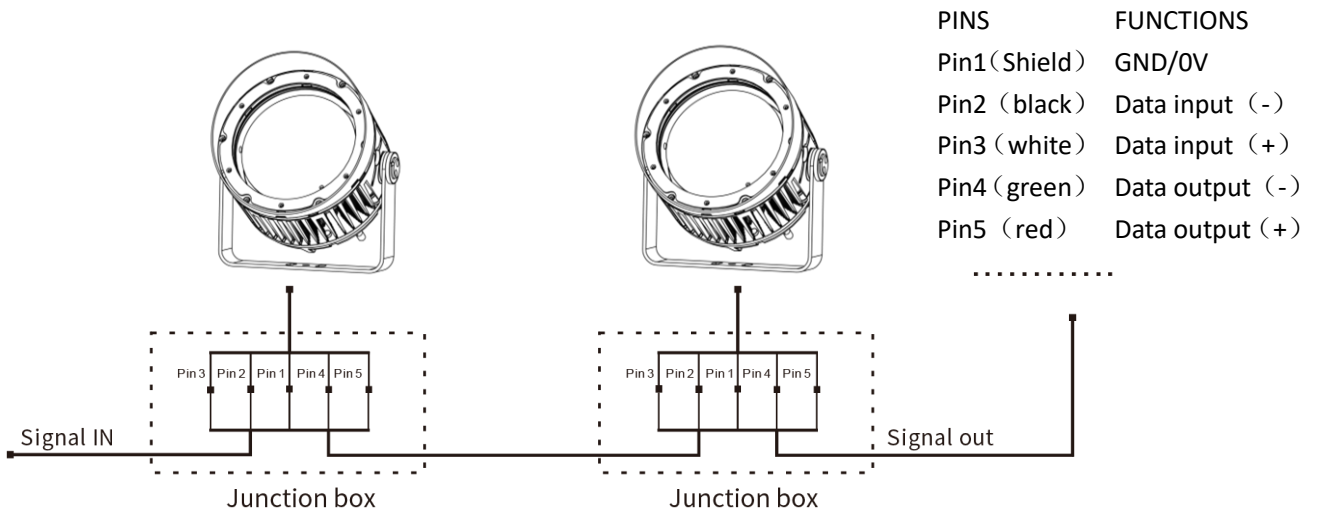

3 USING A DMX512 CONTROLLER

3.1 DMX CONTROL

Note: This product has seven DMX512 channel configurations: ARC1,ARC1+D,ARC2,ARC2+D, SOLID, ARC FULL,SPECIAL2.

DMX Modes		SOLID	ARC1	ARC1+D	ARC2	ARC2+D
CHANNEL	VALUE	FUNCTION				
1	0-255	ALL LED	RED	DIMMER	RED	DIMMER
2	0-255		GREEN	RED	GREEN	RED
3	0-255		BLUE	GREEN	BLUE	GREEN
4	0-255		BLUE	WHITE/AMBER/ LIME	BLUE	
5	0-255					WHITE/AMBER/ LIME

ARC FULL	SPECIAL2	VALUE	FUNCTION
CHANNEL			
1	1	0-255	DIMMER
2	2	0-255	RED
3	3	0-255	GREEN
4	4	0-255	BLUE
	5	0-255	WHITE/AMBER/LIME
5	6	PRESET COLOR	
		0-10	NO FUNCTION
		11-255	PRESET COLOR
6	7	CCT	
		0-9	NO FUNCTION
		10	1800K
		10-25	1800-2200K Linear transition
		25	2200K
		25-40	2200-2700K Linear transition
		40	2700K
		40-55	2700-3000K Linear transition
		55	3000K
		55-70	3000-3200K Linear transition
		70	3200K
		70-85	3200-4000K Linear transition
		85	4000K
		85-100	4000-4500K Linear transition
		100	4500K
100-115	4500-5000K Linear transition		
115	5000K		

		115-130	5000-5600K Linear transition
		130	5600K
		130-145	5600-6000K Linear transition
		145	6000K
		145-160	6000-6500K Linear transition
		160	6500K
		160-175	6500-7000K Linear transition
		175	7000K
		175-190	7000-8000K Linear transition
		190	8000K
		190-205	8000-10000K Linear transition
		205-255	10000K
7	8	0-9	NO FUNCTION
		10-255	1-25Hz
		CONTROL (EXECUTE AFTER 3 SECONDS)	
		000-010	NO FUNCTION
		011-100	RESERVED
		101-110	DIMMER OFF
		111-120	DIMMER DIM4
		121-255	RESERVED
8	9		

Annex 1

PRESET COLOR	Value	Color Names	x	y	
	0-10	NO FUNCTION			
	11-15	RESERVE	Loving Amber	0.407	0.321
COLOR 1	16-20	R40	Light Salmon	0.499	0.321
COLOR 2	21-25	L24	Scarlet	0.561	0.296
COLOR 3	26-30	L164	Flame Red	0.659	0.302
	31-35	RESERVE	Easy White	0.389	0.344
	36-40	RESERVE	Warm Peach	0.448	0.353
COLOR 4	41-45	L08	Dark Salmon	0.498	0.347
COLOR 5	46-50	L25	Sunset Red	0.566	0.359
	51-55	RESERVE	Medium Bastard Amber	0.37	0.335
COLOR 6	56-60	L237	CID(To Tungsten)	0.43	0.365
COLOR 7	61-65	R321	Soft Golden Amber	0.477	0.406
COLOR 8	66-70	L652	Urban Sodium	0.535	0.399
	71-75	RESERVE	LCT Yellow(Y1)	0.34	0.363
COLOR 9	76-80	L765	LEE Yellow	0.389	0.412
COLOR 10	81-85	L513	Ice And A Slice	0.38	0.447
	86-90	RESERVE	Spring Yellow	0.41	0.502
	91-95	RESERVE	LEE Plus Green	0.324	0.388
	96-100	RESERVE	CalColor 30 Green	0.318	0.44
	101-105	RESERVE	Fern Green	0.234	0.543
COLOR 11	106-110	L90	Dark Yellow Green	0.184	0.641
	111-115	RESERVE	LEE Fluorescent3600K	0.286	0.37
COLOR 12	116-120	R92	Tuiquoise	0.235	0.36
	121-125	RESERVE	Kelly Green	0.185	0.459
	126-130	RESERVE	Forest Green	0.162	0.496
	131-135	RESERVE	Cosmetic Aqua Blue	0.3	0.318
COLOR 13	136-140	L728	Steel Green	0.256	0.302
COLOR 14	141-145	L117	Steel Blue	0.223	0.278
COLOR 15	146-150	L354	Special Steel Blue	0.173	0.265
	151-155	RESERVE	Paler Lavender	0.284	0.284
COLOR 16	156-160	L501	New Colour Blue	0.246	0.249
COLOR 17	161-165	L174	Dark Steel Blue	0.204	0.205
	166-170	RESERVE	Daylight Blue	0.159	0.158
	171-175	RESERVE	Pale Lavender	0.288	0.254
	176-180	RESERVE	Surprise Pink	0.24	0.183
COLOR 18	181-185	L142	Pale Violet	0.209	0.148
	186-190	RESERVE	Perfect Lavender	0.177	0.07
	191-195	RESERVE	Light Pink	0.335	0.289
COLOR 19	196-200	L794	Pretty'n Pink	0.335	0.251
COLOR 20	201-205	L328	Follies Pink	0.335	0.18
	206-210	RESERVE	Magical Magenta	0.327	0.138
	211-215	RESERVE	Pale Rose	0.35	0.318
COLOR 21	216-220	L127	Smokey Pink	0.397	0.265
COLOR 22	221-225	L192	Flesh Pink	0.41	0.237
	226-230	RESERVE	Special Rose Pink	0.465	0.193
	231-235	RESERVE	Moroccan Pink	0.378	0.324
COLOR 23	236-240	L157	Pink	0.457	0.272
COLOR 24	241-245	R332	Cherry Rose	0.489	0.295
	246-250	RESERVE	Cool LED Bright Pink	0.57	0.263
	251-255	NO FUNCTION			