

NEW

# NEPTUNE 300 BEAM

## SS9461SCM



### PRODUCT INTRODUCTION

NEPTUNE 300 BEAM is an ultra-compact IP beam moving head, which deliver unbelievable strong and powerful output, provide a solid fat, sharp and clean at 2°. It has a super-fast and precise X/Y movement, fast gobo-color effect and clean projection, plus the dual-prism overlay effect. It is an idea product for outdoor performance and landscape lighting. LED waterproof moving head beam lights has a broad market in live performances, cultural tourism markets, theme parks and other places.

### PRODUCT PARAMETERS

#### Optical system

Light source LED 200W  
Angle 2°

#### Appearance

Size 411x280x603mm  
Weight 28kg  
Casing Flame-retardant plastic (V0)  
Die-cast aluminum  
Color Black

#### Electrical Specs

Voltage AC100-240,50/60Hz  
Max. Power 320W  
Power Connection Power in/out  
Signal socket 3pin or 5pin in and out,  
RJ45 in and out

#### Control System

Pan/Tilt rotation 540°/270°(8-16bit)  
Dimmer 0-100%16Bit  
Cooling Direct Convection  
Control DMX/RDM/ARTNET/sACN/W-DMX (可选) , Web, Serve

Display On Board Control, Custom Mode, 0-25Hz Strobe  
Con Personality BASIC/13CHS. STANDARD/18CHS. Extend/19CHS

#### Effect synthetic system

Rotating Gobo 8 Gobos+ White, Gobo-flow effect, Gobo shake,  
Bi-directional rotation  
Colors One color wheel(9 dichroic -filters+ White,  
Rainbow-flow effect)  
Prism 1pc 8+16 facet prism  
1pc linear prism

Focus Motorized linear focus  
Color Effect Wheel Rainbow Color Wheel

#### Certification

CE, MET

#### Work Environment

Ambient Temp -20°C-45°C  
IP Rated IP65

### ILLUMINANCE AT DISTANCE

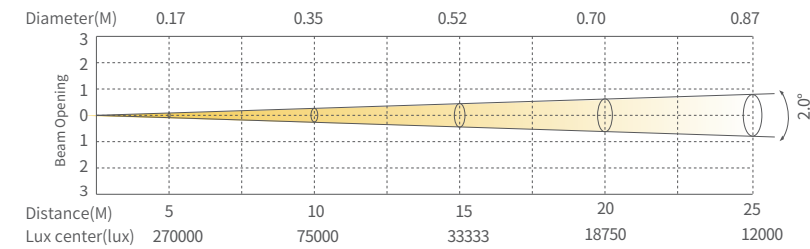

### COLORS



#### Rainbow Color Wheel



#### Rainbow Color Wheel



### DIMENSIONS

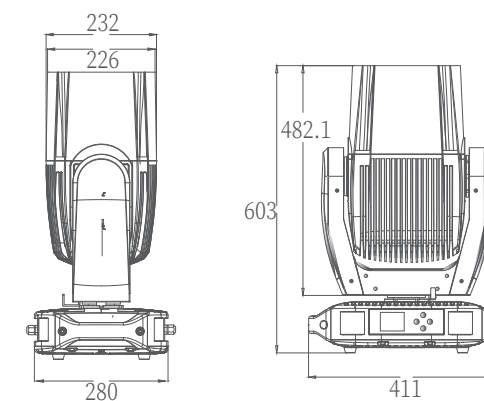

### ACCESSORIES (Accessories not included unless otherwise stated)

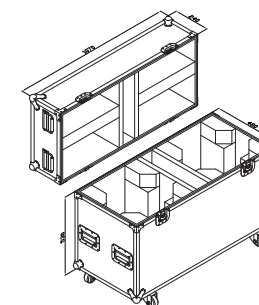

Flight case  
(1320400263)  
Wireless receiver Kit  
(2440010465)