



E8

**PRODUCT INTRODUCTION**

EIDOLON 800 is a high-power outdoor LED Gobo projector with IP66 waterproof rating in the die-cast magnesium alloy. It is forced air cooling with a low noise fan. Built-in electronic zoom 5-52° and automatic focusing system, which apply to large area long-range projection; Equipped with CMY color mixing system, 6 colors, 14 rotating gobos, animation wheel, and prisms, which can achieve colorful animation effects; Equipped OLED display with touch button. Apply to theme parks, amusement places, landmark building, commercial buildings, outdoor performances, etc.

**DIMENSIONAL DRAWING**

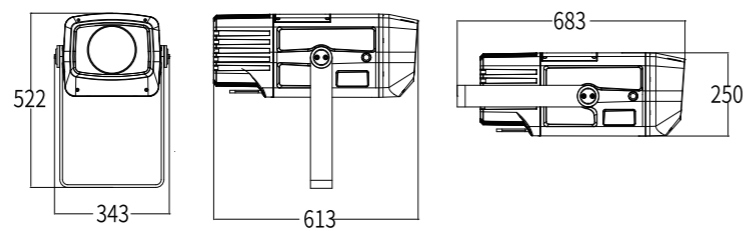

**Eidolon 800**  
AG1681SCT

**Eidolon 800 Pro**  
AG1681SCT-P

**TECHNICAL PARAMETER**

Max. Power	750W	750W
Light source	600W(cool white LED module)	600W(cool white LED module)
Zoom	5°-52°(motorised linear zoom)	5°-52°(motorised linear zoom)
Display	On board Control, 0-25Hz Strobe	On board Control, 0-25Hz Strobe
Con personality	STANDARD(24CHS), BASIC(20CHS)	STANDARD(24CHS), BASIC(20CHS)
Rotating Gobos	2 rotating gobo wheels (7+open interchange glass gobos), Gobo-flow effect, Gobo shake, Bi-directional rotation	2 rotating gobo wheels (7+open interchange glass gobos), Gobo-flow effect, Gobo shake, Bi-directional rotation
Color wheel	One color wheel (6 dichroic-filters+open, Rainbow flow effect)	One color wheel (6 dichroic-filters+open, Rainbow flow effect)
CCT	Linear CTO 2700K-6500K	Linear CTO 2700K-6500K
Prism	One 4 prism with bi-directional rotation, Speed adjustable	One 4 prism with bi-directional rotation, Speed adjustable
Color mixing	CMY, independently variable 0 - 100%	CMY, independently variable 0 - 100%
Focus	Motorized linear focus	Motorized linear focus
Animation Wheel	Bi-directional rotation, Speed adjustable	Bi-directional rotation, Speed adjustable
Frost	1 motorized frost filter	1 motorized frost filter
Dimensions (L*W*H)	683x343x522mm	683x343x522mm
Shutter system	No	4 manual shutter blades

**COLORS**



**CMY+CTO**



**RATATING GOBO WHEEL 1**



**RATATING GOBO WHEEL 2**

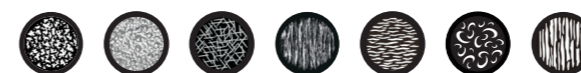

**ANIMATION WHEEL**      **MANUAL FRAMING SYSTEM (EIDOLON 800 PRO)**



**SPECIFICATIONS**



**ILLUMINANCE AT DISTANCE**

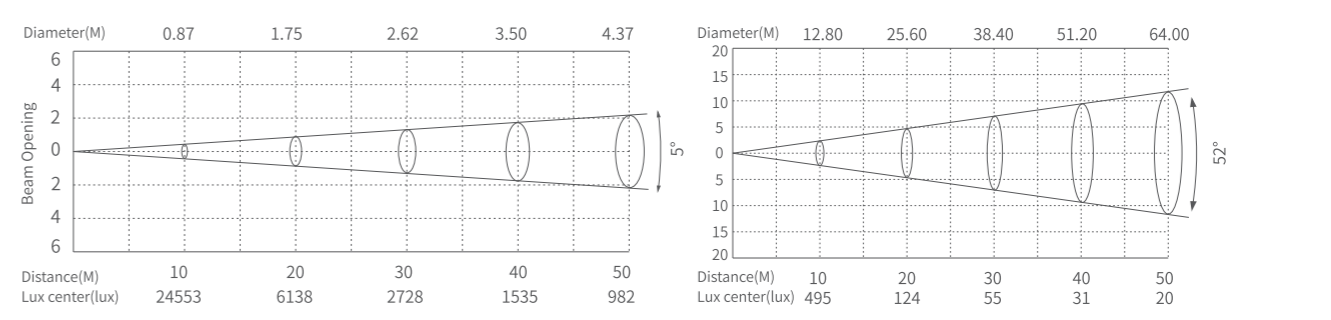

**OPTIONAL ACCESSORIES**



Wireless Kit  
(2440010832)